

BSA SERVICE SHEET No. 710

Oct., 1948

Reprinted June, 1960

All Models CHAIN ALTERATIONS AND REPAIRS

A chain rarely breaks if it is kept properly lubricated and adjusted. Usually it is worn out long before it reaches breaking point. The rear chain is the most heavily stressed and is therefore the one most likely to give trouble. Spare parts should be carried to enable the rider to carry out a repair on the road with the aid of a chain rivet extractor (see Fig. X7). The front chain will probably be worn out before it requires shortening.

How to use the chain rivet extractor

First press down lever A (Fig. X7) to open the two jaws (B). Insert the link to be removed so that the jaws grip the roller and support the uppermost inner side plate. The punch (C) is then screwed down on to the rivet head until the rivet is forced through the outer plate.

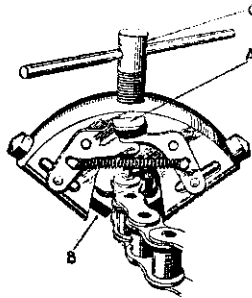

Fig. X7.

To shorten a worn rear chain

After a big mileage, the rear chain may have stretched so that no further adjustment is possible by the usual method. In this case it is possible to shorten the chain by one link or pitch, so increasing its useful life. First remove the single connecting spring link (A) securing the two ends of the chain (Fig. X8). If the chain terminates in two ordinary links as in Fig. X8 (in which case the chain will be of an even number of pitches) extract the third and fourth rivets (B) from the end and replace the detached three pitches by a single connecting link (C). The connection is made with an additional spring link (D). If one end of the chain has a double cranked link (Fig. X9)—in which case the

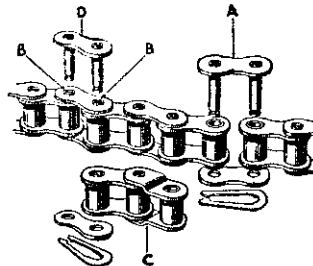

Fig. X8.

chain will have an odd number of pitches—extract the second and third rivets (A), releasing the cranked link unit complete, which can be retained for further use. Replace with one inner link (B) and again connect up with an additional single connecting link (C).

To repair a damaged chain

If a roller or link has been damaged (X, Fig. X9) remove rivets (D), take out the damaged link and replace with one inner link, secured by two single connecting links.

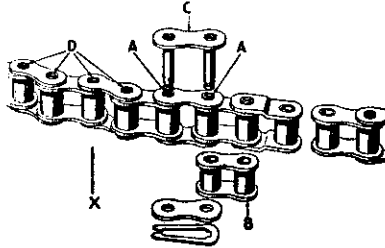

Fig. X9.

It is important that the spring clip fastener should always be put on so that the CLOSED end faces the direction of travel of the chain—i.e., when clip is on top run of chain, closed end is toward front of machine—when clip is on bottom run, closed end is towards rear of machine.

It should be noted that once a rivet has been extracted it must not be used again, so that it is important to check that the correct rivet is being removed before actually removing it. In the case of double cranked links, the complete unit comprises an inner link and the cranked outer link—three rollers in all—and these must never be separated.

Fitting rear chain

To fit a new rear chain, turn wheel until the spring link of the old chain is located on rear sprocket. Disconnect, and allow the lower run to drop down. Join the top run of the old chain to the new chain by means of the connecting link, and then by pulling on the bottom run of the old chain the new one will be carried round gearbox sprocket. Then the old chain can be disconnected and the ends of the new one joined together.

When the rear chain breaks and falls from its sprockets, the new or repaired chain can be replaced without taking off the chainguards. One end of the chain must be fed (from the rear) under the front end of the rear top chainguard on to the gearbox sprocket. A long bladed screwdriver or a piece of stiff wire may assist this operation. When the chain has located on the sprocket teeth, engage a gear and gently turn gearbox over with the kick-starter. This will feed chain round gearbox sprocket. When sufficient length of chain is hanging below sprocket, disengage gear and chain can then be pulled round until both runs can be fed inside rear chainguard and engaged on rear wheel sprocket.

B.S.A. MOTOR CYCLES LTD.
Service Dept., Waverley Works,
Birmingham, 10

Printed in England.



SERVICE SHEET No. 710x

June 1948.

Revised May 1954.

Revised Mar. 1958.

FRAME REPAIRS

ALL MODELS

Frame repairs must not be attempted unless adequate workshop facilities are available.

The information given in this sheet is intended for the use of Dealers who are unable to take advantage of the B.S.A. repair service and who have frame repair facilities.

Spotting points to enable frame trueing to be carried out can be determined by making use of the dimensions given.

B.S.A. Motor Cycles Ltd., Birmingham 11.

(PRINTED IN ENGLAND)

**A7-10
RIGID FRAME**

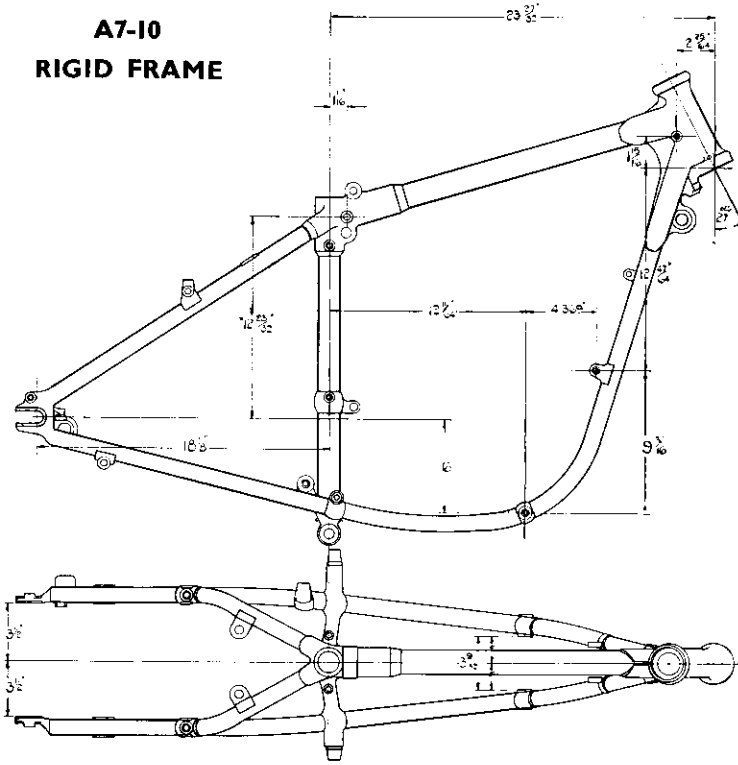

**A7-10
SPRING FRAME**

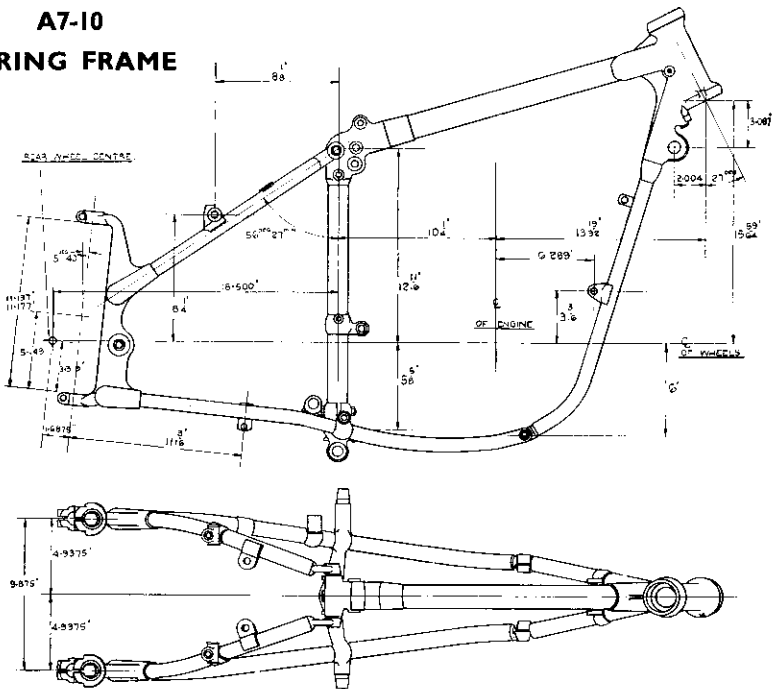

**1953 SUPER FLASH
SPRING FRAME**

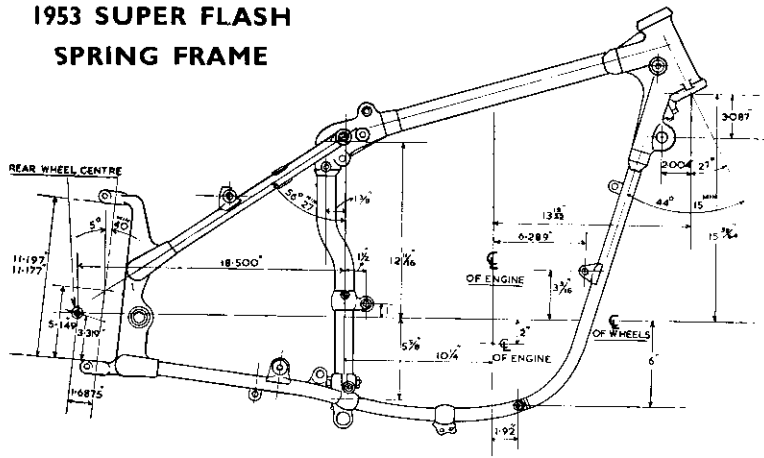

1953 SUPER FLASH,
(SPRING FRAME)

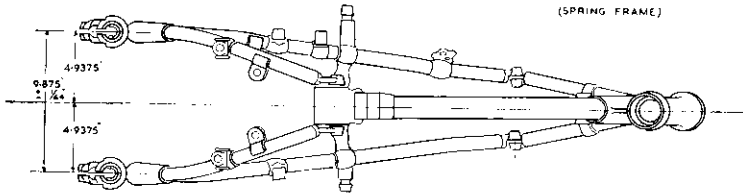

**M20, M21 and M33
RIGID FRAME
1945 - 1948**

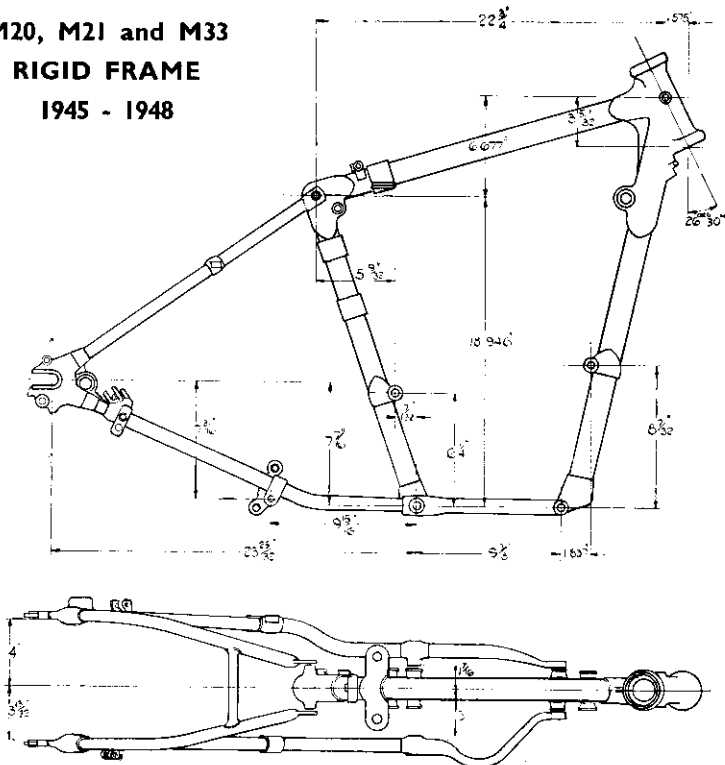

**M20, M21 and M33
RIGID FRAME
1949 onwards**

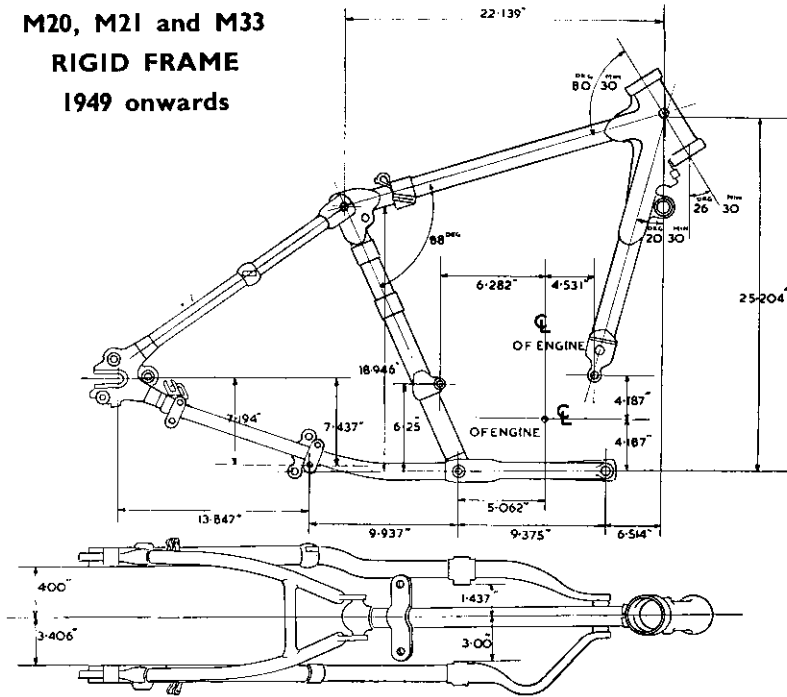

**M20, M21 and M33
SPRING FRAME**

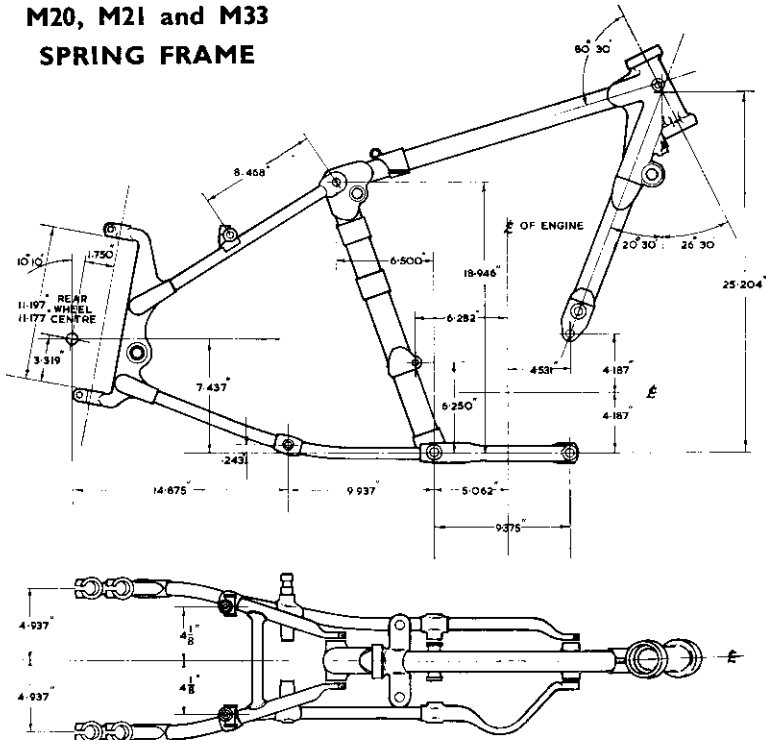

**DI and D3
RIGID FRAME**

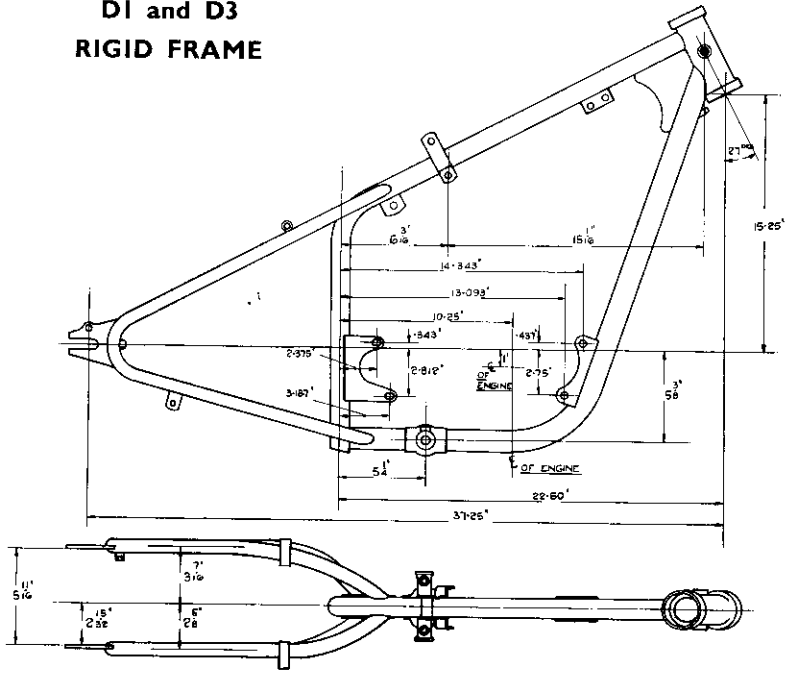

**DI and D3
SPRING FRAME**

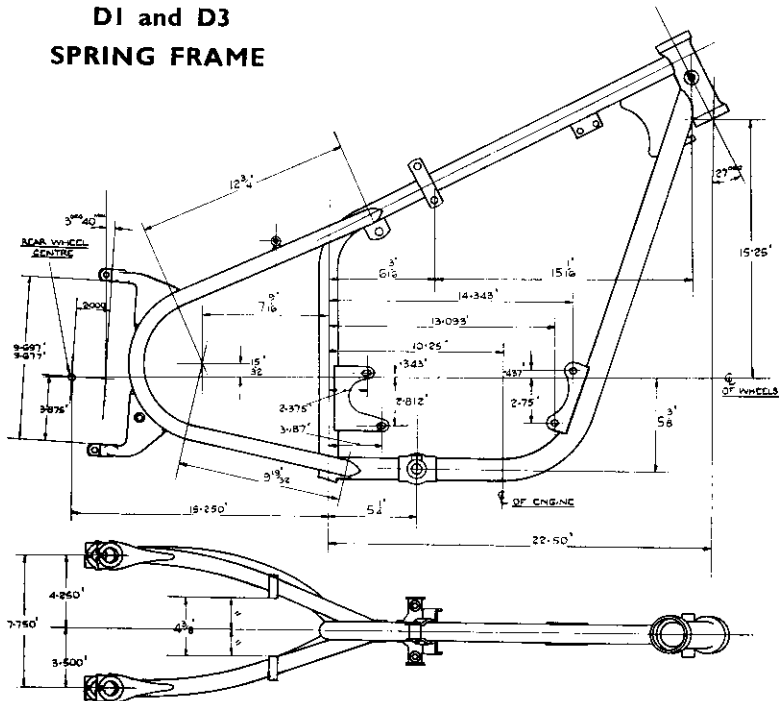

**CI0L
SPRING FRAME**

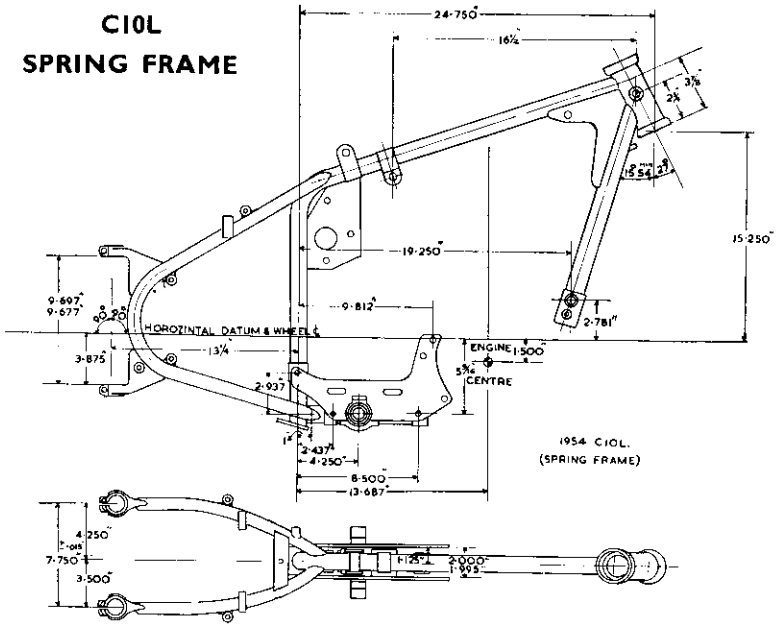

1954 CI0L.
(SPRING FRAME)

**CI0, CI1, CIIG
RIGID FRAME**

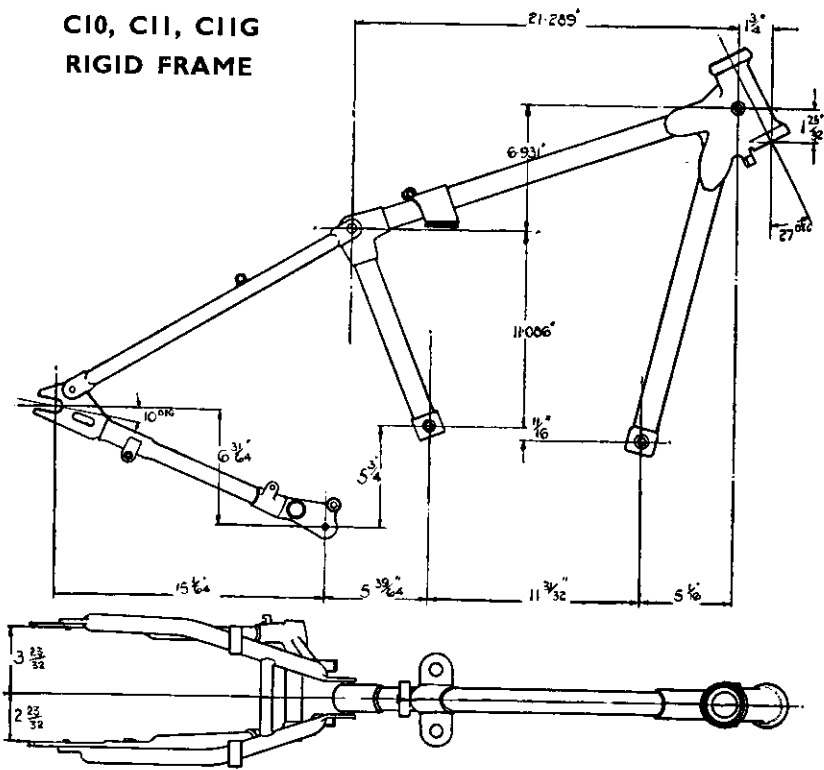

**C10, C11, C11G
SPRING FRAME
3 SPEED GEARBOX**

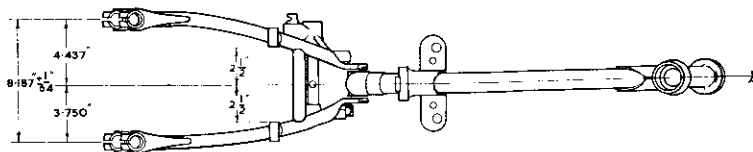
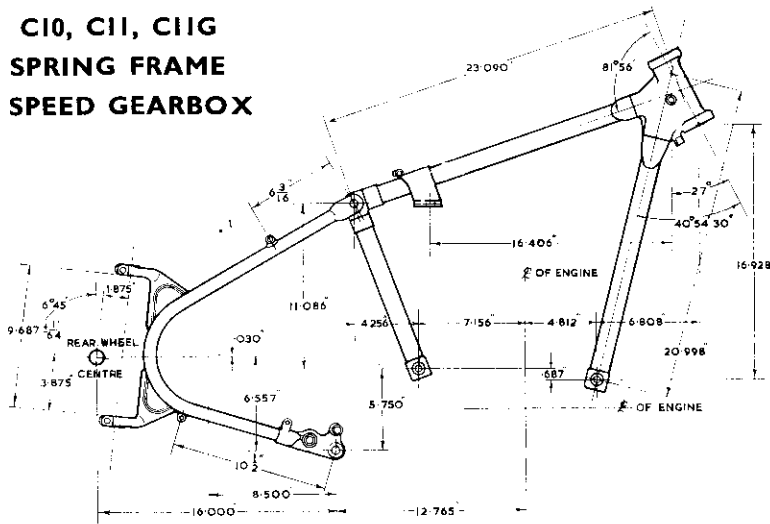

**C10, C11, C11G
SPRING FRAME
4 SPEED GEARBOX**

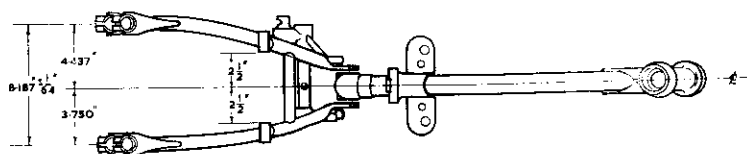
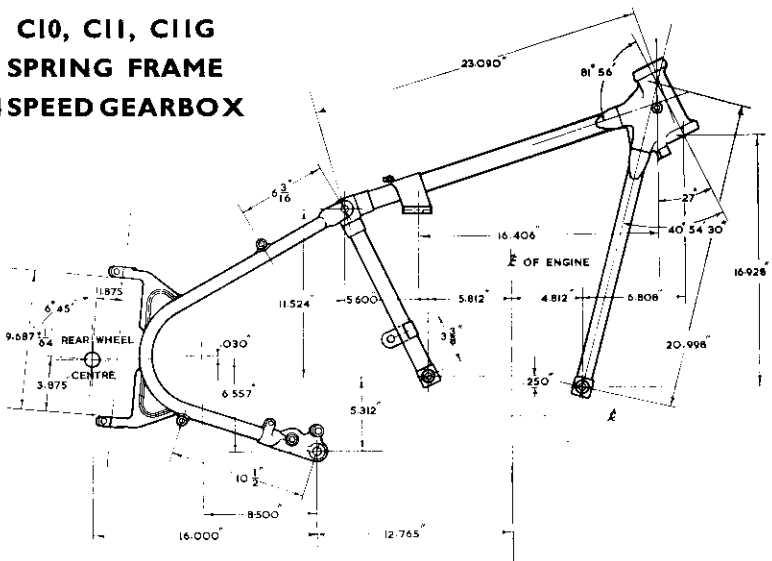

1953 GOLD STAR SWINGING ARM

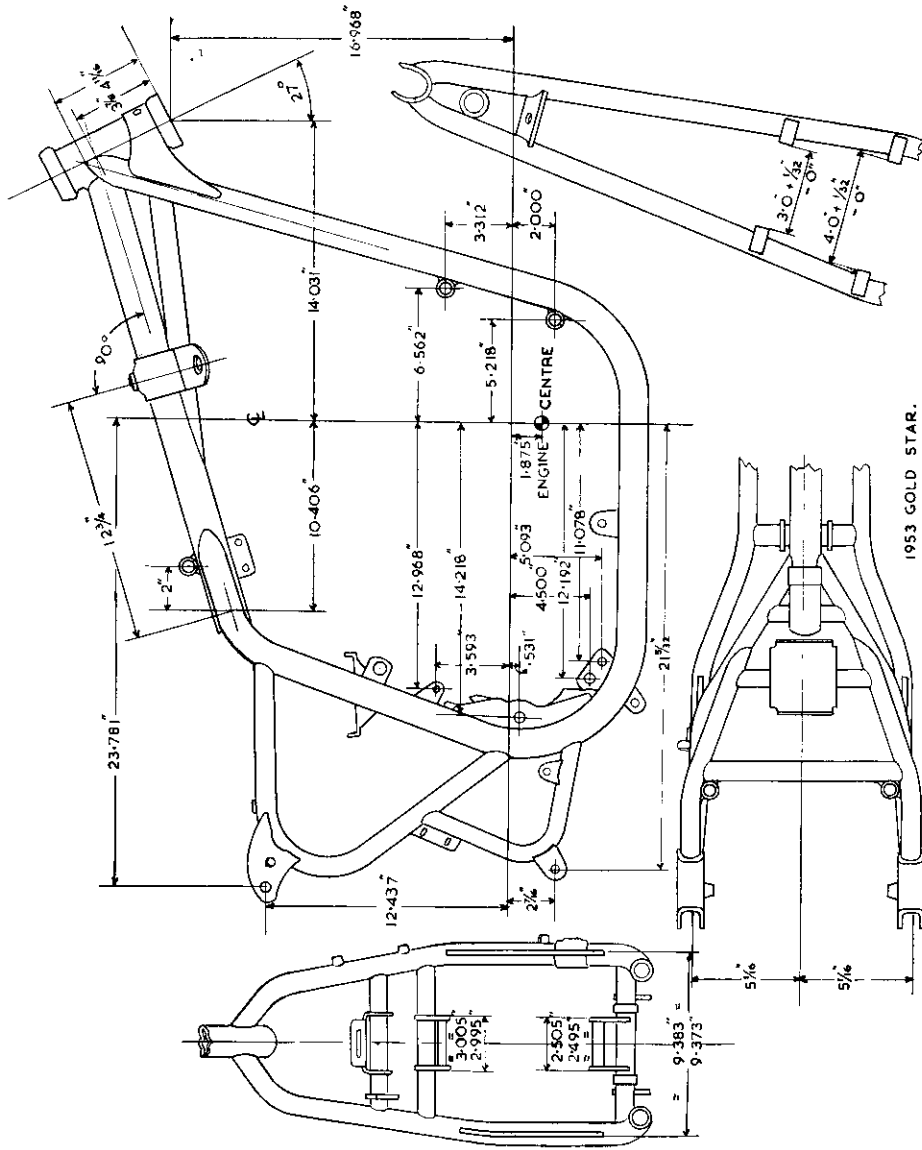

A GROUP, B GROUP and GOLD STAR 1954 SWINGING ARM

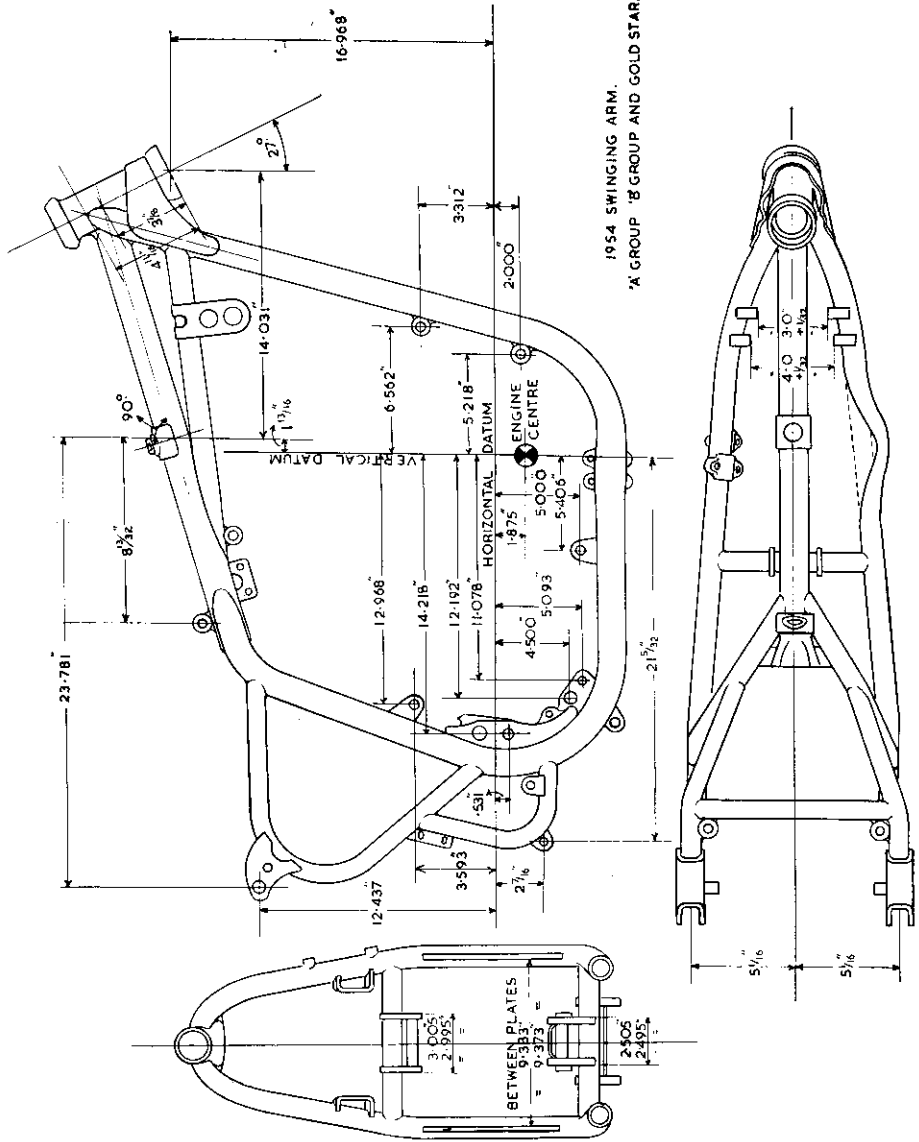

1954 SWINGING ARM.
"A" GROUP "B" GROUP AND GOLD STAR.

**B32 and B34
1954 RIGID FRAME**

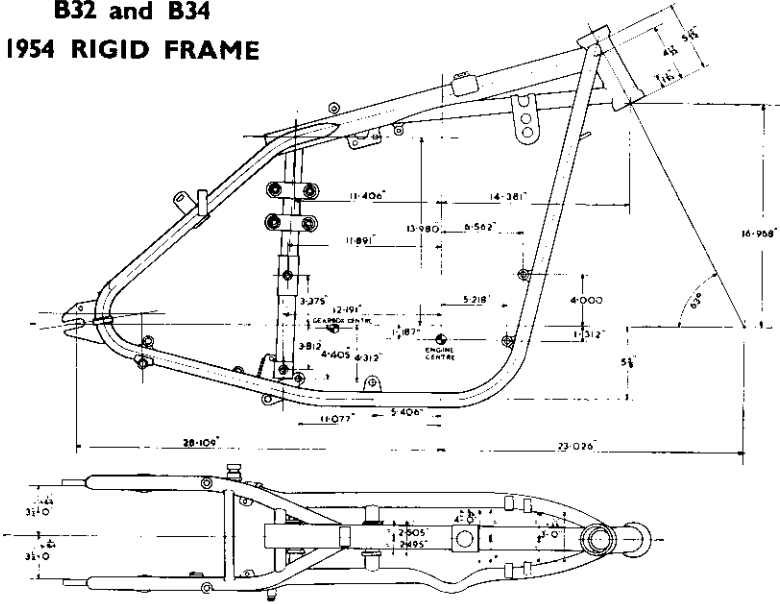

D3 SWINGING ARM

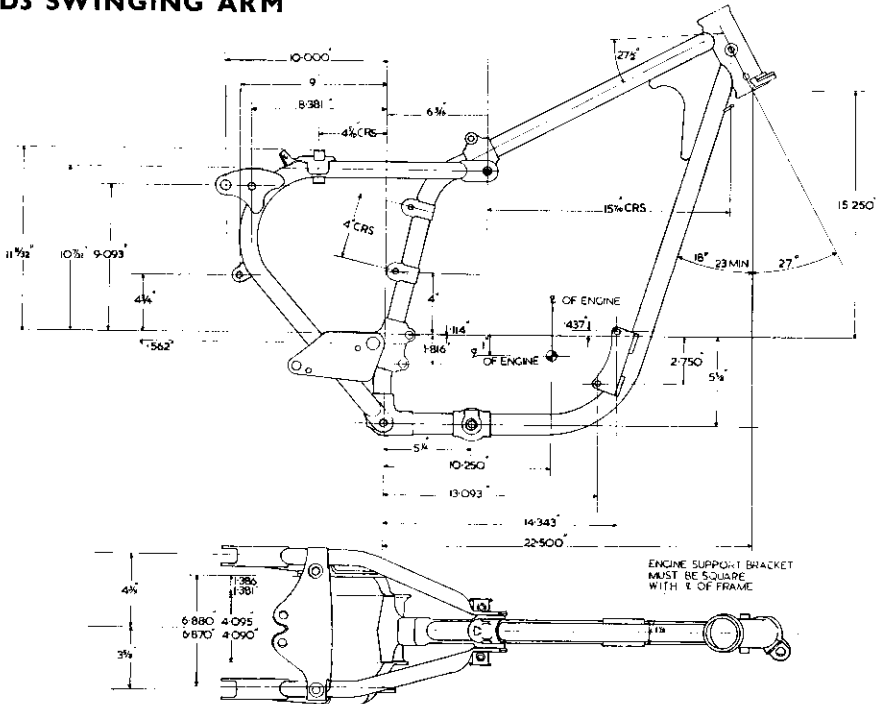

**B32 and B34
1954 RIGID FRAME**

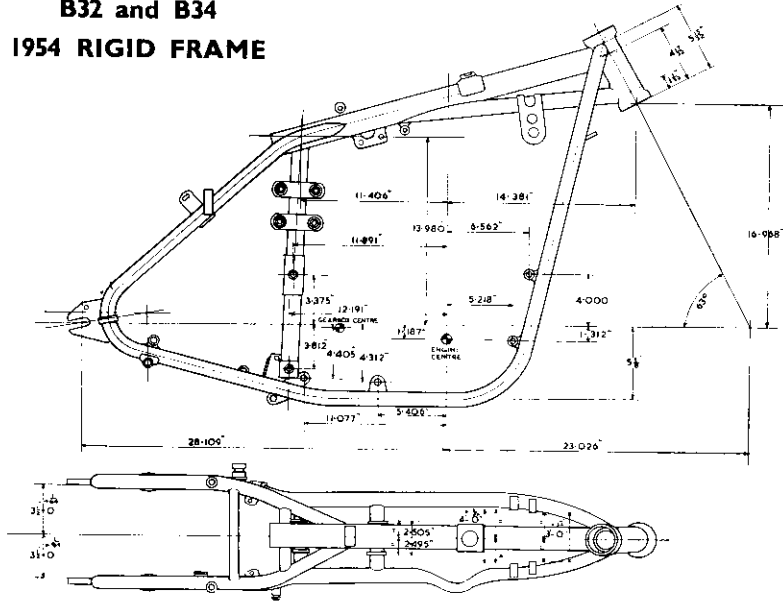

D3 SWINGING ARM

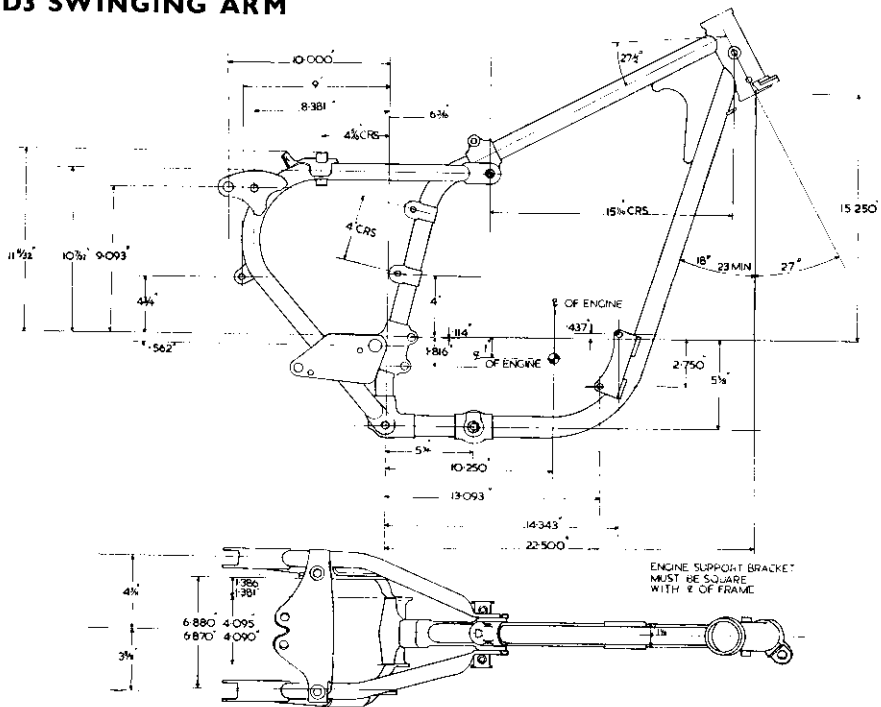

CI2 SWINGING ARM

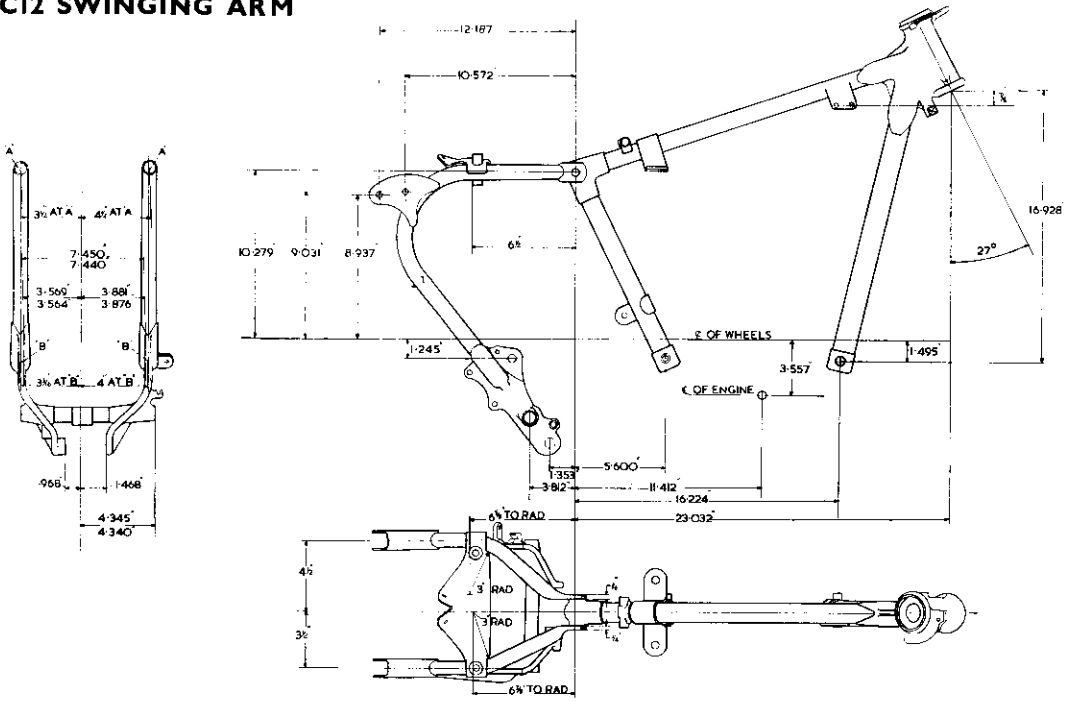

D5 SWINGING ARM

